

Lighting

Lighting provides a tool for setting the mood of a scene. The responsibility of hanging and focusing the lights for a show falls on the hang crew overseen by the **master electrician (M.E.)** There are many different types of lighting instruments that the M.E will use in the theatre. Each type of instrument plays an important role in the overall lighting scheme. It is important that the M.E. has a broad understanding of all of these instruments, how they are installed, and how they are focused. One of the instruments that you will use the most is the **ellipsoidal reflector spotlight**. There are many types of ellipsoidals from different manufacturers and different eras; one of the most common is the **ETC Source 4 Ellipsoidal Spotlight**.

Tech Challenge Event: Hang and focus a lighting instrument

Individual Event

Two people per team can try this event; best time counts for team score



ETC Source 4

The master electrician uses many different kinds of lighting instruments. In this challenge, participants will be asked to successfully hang and focus an ETC Source 4 Ellipsoidal Spotlight. All equipment and tools will be provided, but participants can bring their own gloves

Rules

1. Participants must not step past the tape which indicates the edge of the **catwalk**.
2. Participants must wear gloves on both hands at all times and use adjustable crescent wrenches. No speed wrenches or fingerless gloves.
3. Participants must tether their wrench when it is out and put it in a pocket when not in use. All wrenches brought must be attached to an 18" minimum tie line tether when in use. Items should never be tethered around a participant's neck or over the shoulder.
4. Participants must not carry gel frames in a pocket
5. Participant must provide the sharpest possible focus of the fixture.
6. Follow the sequence and additional instructions below.

Note: The safety cable must be placed on the equipment table separate from the fixture during event set up.

When the unit is secured properly to the pipe, powered on, correctly focused to the shape marked out on the wall and the excess cable properly dressed then the event has been successfully completed. The ETC Source 4 Ellipsoidal has a drop-in iris slot on the top of the fixture. The gel clip holder should also be on this side of the fixture. The gel clip holder needs to be on top of the fixture when it is focused.

The maximum time allotted is **five minutes**. For a video demonstration of general technique, visit <http://www.youtube.com/watch?v=OPsv-jvXzc8>. Some elements of our event will be different.

How to hang an ETC Source 4 Ellipsoidal Spotlight:

1. Place **C-clamp** over the pipe at the designated hanging location. The opening of the C-clamp must face the person installing the fixture, enabling unobstructed access to bolts.
2. Finger tightened the pipe bolt
3. Attach the **safety cable** through the **yoke** and around the electric pipe while keeping one hand on the instrument
4. Tighten the pipe bolt and adjust the C-clamp as necessary so that it is secure on the electric pipe. Pipe bolt should be no tighter than a quarter turn past finger tight.
5. Pull all of the shutters in the fixture to open.
6. Plug the **tail** of the lighting instrument into the designated **circuit**.

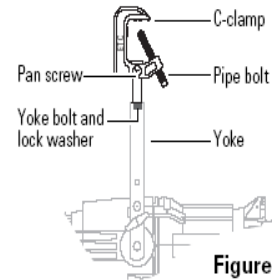

Figure 9

How to focus an ETC Source 4 Ellipsoidal Spotlight:

1. Adjust the **pan** of the unit so that it is set in the desired location.
2. Adjust the **tilt** of the unit so that it is set in the desired location.
3. **Focus** the **beam** to the desired beam edge.
4. Using the **shutters** and the rotation knob as necessary, shape the beam to the desired shape and angle.
5. Make sure all nuts, handles and knobs are tightened so the instrument does not **drop focus**.
6. Drop **color** in to the color slot of the instrument.

How to set the angle within the yoke:

1. Loosen the yoke locking knobs. Do not remove them.
2. Tilt the fixture to the desired position.
3. Tighten the yoke locking knobs to secure the fixture in position.

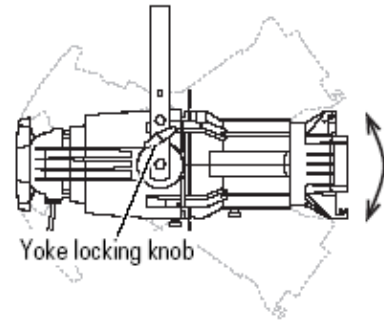

How to focus the beam:

1. Loosen the beam focus knob located under the barrel.
2. Slide the lens tube forward or backward to achieve the desired beam edge.
3. Once the fixture is focused, tighten the beam focus knob.

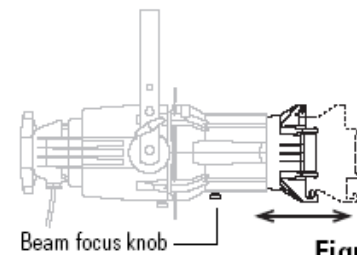

Figure 4

How to rotate the angle within the fixture:

1. Loosen the rotation locking knob. Do not remove it.
2. Rotate the barrel of the fixture left or right to the desired position.
3. Recheck the focus of the beam for sharp or soft focus and then tighten the rotation locking knob to secure the fixture in position.

How to coil and dress a cable

1. Cable should be coiled with correct "over/under" technique. See video for instruction: <https://m.youtube.com/watch?v=pEd7ru24Vx0>
2. Once cable is properly coiled, it should be secured to the pipe with tie line or cable tie

Required sequence

1. Participants can ask questions prior to start.
2. Leave the starting line on the judges' call and put on gloves.
3. Locate the fixture.
4. Hang the fixture.
5. Hand-tighten the C-clamp.
6. Install the safety cable.
7. Wrench tighten the C-clamp.
8. Check and tighten as necessary the yoke bolt on the side and bottom of the C-clamp.
9. Open the shutters on the fixture.
10. Plug the fixture into power.
11. Position the fixture to illuminate the shape.
12. Lock the fixture. Loosen and tighten the pan screw on the C-clamp or the rotation knob as necessary.
13. Place the fixture in a sharp focus.
14. Make shutter cuts as necessary.
15. Review fixture focus and make adjustments as necessary.
16. Insert gel frame.
17. Properly coil excess cable and dress onto pipe
18. Return to starting line.
19. Assist judges in restoring all equipment to pre-event conditions.

Penalties: Hang and focus a light

Add the following time for:

Moving in front of hang pipe, stepping past tape	25 seconds
Placing items in mouth	10 seconds
Dropping items or placing on the ground	10 seconds
Gloves not worn beginning to completion	10 seconds
Items tethered around neck	10 seconds
Wrench not tethered	10 seconds
Gel frame not installed properly or forgotten	10 seconds
C-clamp opening not facing installer	5 seconds
Instrument hung upside down	15 seconds
Safety cable not used properly	10 seconds
Any item not tightened	10 seconds
Shutters not open prior to power	5 seconds
Shutter cut spilling onto tape	2 seconds
Shutter cut up to 2" inside/outside shape	5 seconds
Shutter cut more than 2" inside/outside shape	10 seconds
Failure to follow sequence	10 seconds
Focus is not sharp	5 seconds
Not keeping a hand on the instrument while attaching safety cable	10 seconds
Cable not properly coiled and dressed	5 seconds
Blatant disregard for the rules	disqualified